

Table of Contents

- Vertical Installation in Rectangular Athletic Fields
- Horizontal Installation in Rectangular Athletic Fields
- Installation in Baseball and Softball Fields
- Installation in Golf Courses and General Landscaping

Vertical Installation in Rectangular Athletic Fields

For existing athletic fields, new fields, or to correct specific areas with poor drainage, 6-inch Hydroway is typically installed.

Vertical Trench

A vertical trench runs through the field at regular intervals for the purpose of collecting excess field water. The trench is 3 to 4 inches wide and ideally 12 to 14 inches deep per row. Hydroway is placed in the trench and the trench is then backfilled with a coarse, clean sand. Soil from the excavation of the trench is removed from the field (See Figures 1 and 5).

Collector Pipe

A collector pipe runs the outside perimeter of the athletic field. Excess water from the field that is collected by the Hydroway empties into the collector pipe for removal to an inlet, storm drain, ditch, or stream.

Fittings

An End Out fitting is used at the end of the Hydroway to transfer water to the collector pipe. A Fabric End Cap is used to cover a cut end of the Hydroway. A Side Outlet empties water from the Hydroway into the collector pipe at any location along the pipe. A Splice is used to connect two ends of Hydroway. All fittings are secured to Hydroway with HydraTape (See Figures 2 and 3).

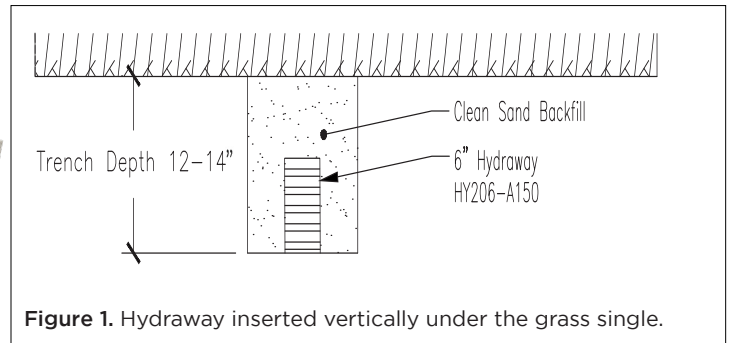

Figure 1. Hydroway inserted vertically under the grass single.



Figure 2. Fittings.

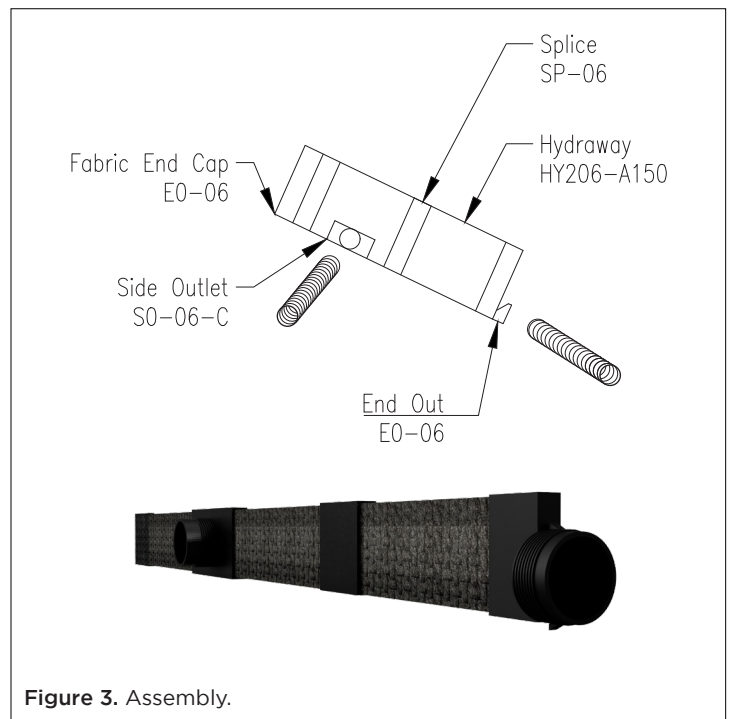

Figure 3. Assembly.

Natural Turf Installation Instructions

Design Variables

When preparing a drainage schematic for new or existing natural turf fields, the slope of the field, spacing, and drainage patterns must be taken into consideration.

Slope of the Field

The greater the slope of a field, the faster the field drains. New and existing fields may require different techniques.

New Rectangular Fields

Most fields such as football and soccer fields are crowned in the center and slope towards the side lines at 0.5 - 1.5% (See Figure 4).

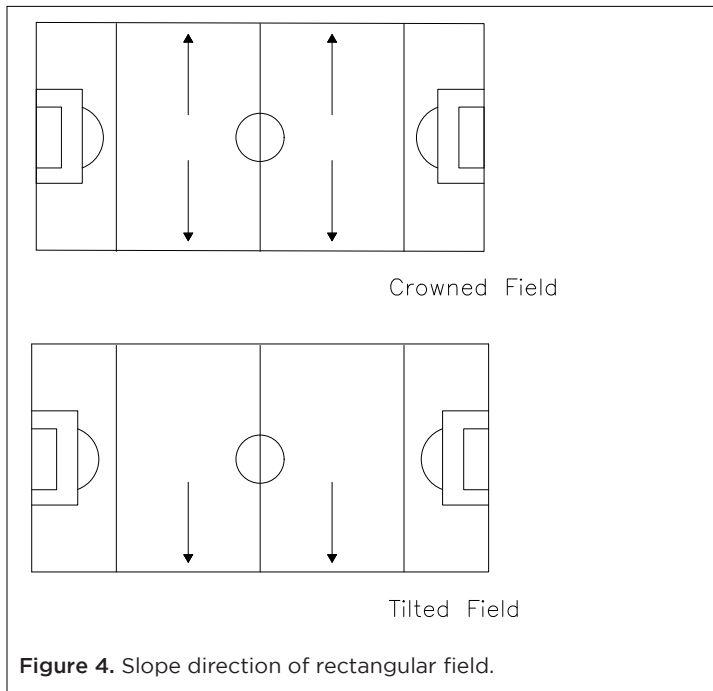

Existing Rectangular Fields

Existing fields that are properly sloped will have an invert that mirrors the top of grade. For existing fields that have little or no slope, trenching on a minimum slope of approximately 0.1% is recommended.

Spacing

Spacing is typically 10 to 15 feet center to center. The drain spacing does not usually exceed 20 feet. However, there are other factors to consider such as field use, annual rainfall, and desired field downtime. Contact Hydraway to assist in the design of the drainage pattern (See Figure 5).

Drainage Patterns

Drainage patterns are dictated by the slope of the field. A herringbone pattern is preferred on a crowned slope and a diagonal pattern is preferred on a tilted field. This will allow water to intersect the drain lines several times, thus improving water collection (See Figure 5).

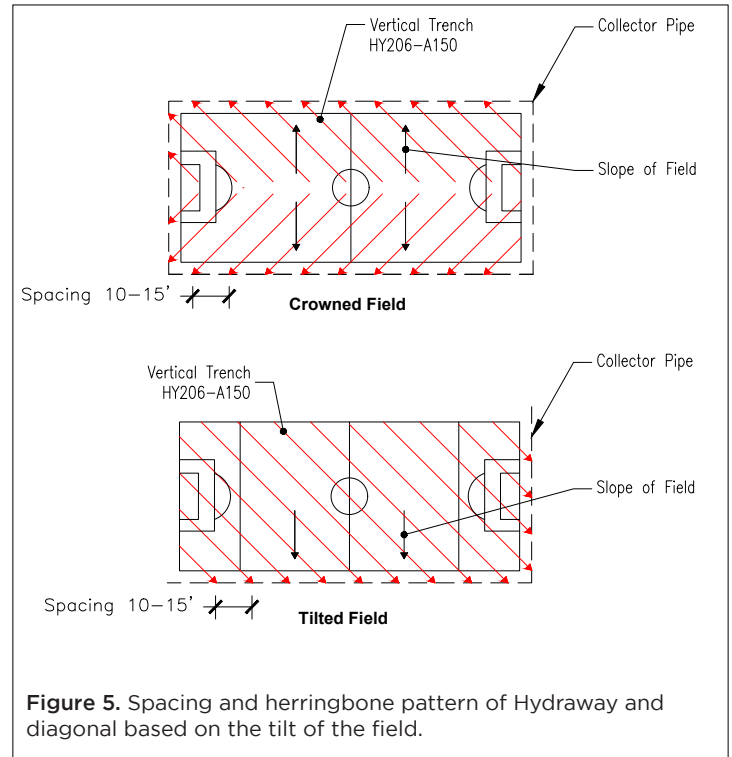

Other Considerations

Irrigation

Hydraway should be installed above an irrigation system.

Aeration

If there are plans to conduct deep tine aeration, Hydraway should be installed deep enough to avoid being damaged. The invert needs to be deep enough to avoid being punctured.

Trench Backfill

Hydraway should be placed in the center of the trench, backfilled with coarse, clean sand, placed on both sides of the drain lines. This is important to keep the fines from the surrounding soils from contaminating the system. The trenches should be backfilled with “coarse” sand. The sand should be clean, free-draining, well-graded, and free of fine-grained soil particles. The perc rate should be 18 to 28 inches per hour. Coarse sand is defined as USGA grade 2 to 5 mm. However, if coarse sand is not geographically available, use small “angular” gravel.

Natural Turf Installation Instructions

Horizontal Installation in Rectangular Athletic Fields

High performance, sand-based fields use a horizontal installation with 12-inch Hydraway (See Figure 6).

The layout of a high-performance sand-based field is designed by an architect or engineer. Contact Hydraway for assistance with the design.

In a horizontal design, there is a top and bottom to Hydraway. The top is the grid of the core, and the bottom is the dimpled points of the core (See Figure 7).

Fittings

An End Out fitting is used at the end of the Hydraway to transfer water to the collector pipe. A Fabric End Cap is used to cover a cut end of the Hydraway. A Splice is used to connect two ends of Hydraway. All fittings are secured to Hydraway with HydraTape (See Figures 8 and 9).

Design Variables

When preparing a drainage schematic for sand-based fields, the slope of the field, spacing, and drainage patterns must be taken into consideration.

Slope of Field

The greater the slope of a field, the faster the field drains. Fields such as football and soccer fields are crowned in the center and slope towards the side lines at 0.5 - 1.0% (See Figure 4).

Spacing

A drain spacing of 10 to 15 feet center to center is typically used. The drain spacing should not exceed 20 feet. However, there are other factors to consider such as field use, annual rainfall, and desired field downtime (See Figure 5).

Drainage Patterns

A herringbone pattern is preferred on crowned sloped fields, allowing water to intersect the drain lines several times, which improves water collection (See Figure 5).

Other considerations

Irrigation

Hydraway should be installed above an irrigation system.

Aeration

If there are plans to conduct deep tine aeration, Hydraway should be installed deep enough to avoid being damaged. Typically, the invert needs to be deep enough to avoid being punctured.

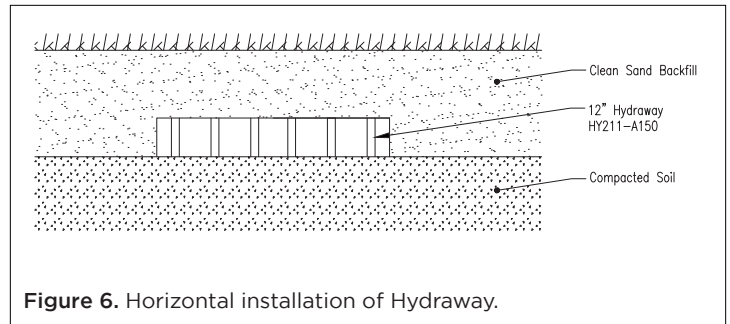

Figure 6. Horizontal installation of Hydraway.

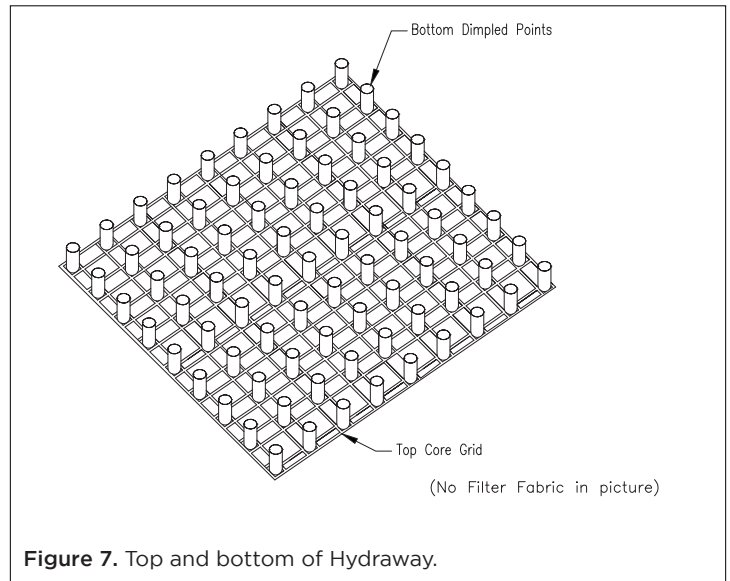

Figure 7. Top and bottom of Hydraway.



Figure 8. Fittings.

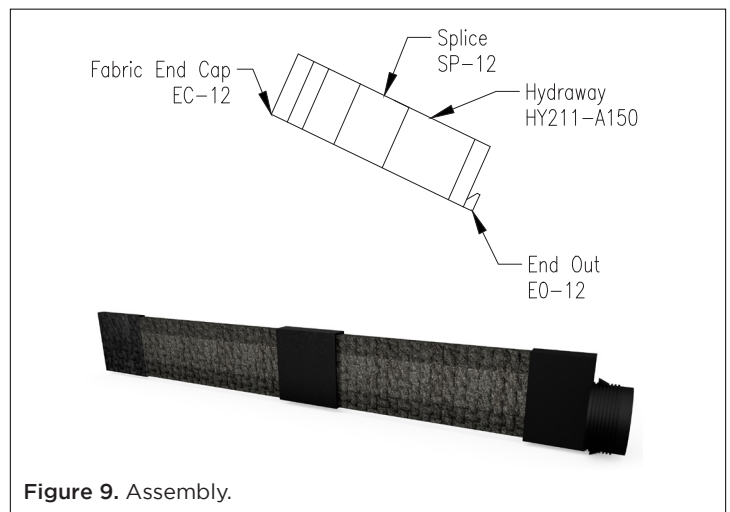
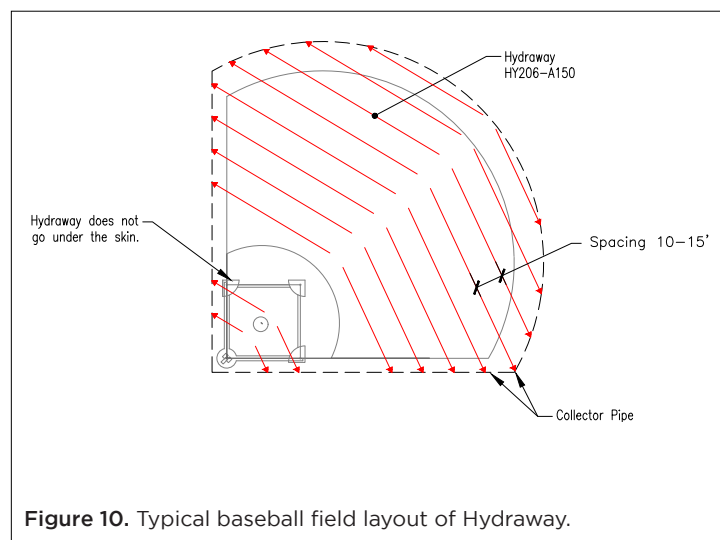

Figure 9. Assembly.

Natural Turf Installation Instructions

Baseball and Softball Fields

See Figure 10 for a typical drainage scheme for a baseball or softball field. This schematic is based on the same principals that are described in the Vertical Installation section. Hydraway is not typically installed on the skins of the field. Vertical Trench spacing on the field is 10-15 feet.



Golf Courses and General Landscaping

Vertical Trench

A vertical trench runs through the drainage area for the purpose of collecting excess water. The trench is 3 to 4 inches wide and ideally 12 to 14 inches deep per row. 6-inch Hydraway is placed in the trench and the trench is then backfilled with a coarse, clean sand. Soil from the excavation of the trench is removed from drainage area (See Figures 1 and 5).

Collector Trench

A collector trench generally runs down the center or at the edge of the drainage area. Excess water collected by the vertical trench empties into the collector trench for easy removal to a nearby inlet, storm drain, ditch, or stream.

Fittings

An End Out fitting is used at the end of the Hydraway to transfer water to the collector pipe. A Fabric End Cap is used to cover a cut end of the Hydraway. A Side Outlet empties water from the Hydraway into the collector pipe at any location along the pipe. A Splice is used to connect two ends of Hydraway. All fittings are secured to Hydraway with HydraTape (See Figures 8 and 9).

Determining the Slope of the Drainage Area

The slope of the drainage area plays a significant role in the drainage schematic. As the surface water travels down the slope, it seeks a vertical drain and quickly enters the Hydraway system. It is important that the slope of the drainage area is intercepted by the vertical drains at approximately 35 to 45 degrees. This ensures that water flowing across the surface will flow into the vertical drain and into Hydraway (See Figure 11).

